

TELESCOPIC FORKS

INDUSTRIES



FUNCTIONS

Lifting
Extending/Retracting
Stabilizing

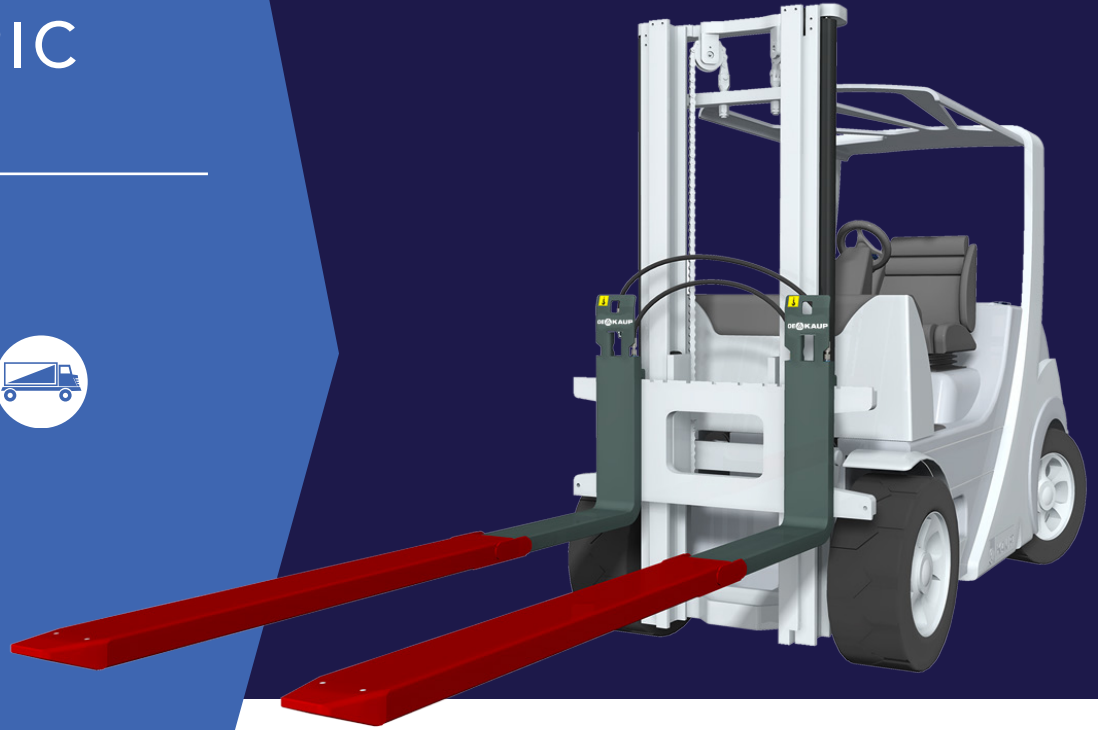

Telescopic Forks enable the stacking of palletized goods to the opposite side of trucks or in double-deep racks. Telescopic Forks increase loading speeds, ensuring quicker loading cycles. These forks can also be used as hydraulic fork extensions for various sized loads or pallets, eliminating the need for fork extensions.

FEATURES & BENEFITS

- **Reduced downtime:** maintenance-friendly design for faster upkeep of attachment; easily access hydraulic connections for quick and simple assembly or disassembly.
- **Optimal efficiency:** forks can be extended or retracted under load; left and right fork are completely synchronized to move together; sliding parts include extended-wear surfaces.
- **Attachment versatility:** can be used as standard forks when extension isn't needed; pallet stop, load stop and load backrest options available.
- **Excellent visibility:** clear view of fork tips for safe and exact operation.

QUICKER and
EASIER than
Fork Extensions

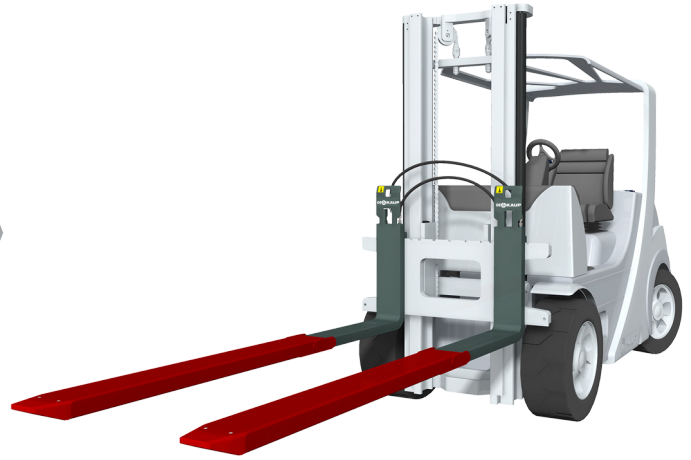

OEA Kaup leads the competition with some of the lowest lost load centers in the industry. Left and right forks are 100% synchronized to ensure consist alignment and both have robust fork shoes running the full length of the bottom of the forks.

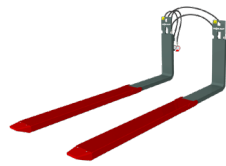

LOW LOST LOAD CENTER

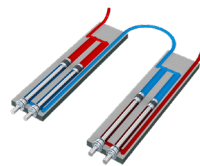

AUTO SYNCHRONIZATION



HARDENED FORK SHOES

Telescopic Forks	Capacity @ 24"	Capacity @ 57"	Capacity @ 69"	Wide in	Thick in	Length in	Length in	ITA Class	Thick in	CofG	CofG	CofG	Weight lb
MINIMUM	4,400 lb	2,090 lb	1,760 lb	--	--	31.5"	47.2"	II	--	--	--	--	--
TFCT-055-4871-2-A	5,500 lb	2,640 lb	N/A	6.4"	2.2"	47.2"	80.7"	II	1.8"	16.5"	22.8"	2.2"	428 lb
TFCT-055-5393-2-A	5,500 lb	2,640 lb	2,200 lb	6.4"	2.2"	53.1"	92.5"	II	1.8"	19.1"	28.4"	2"	463 lb
TFCT-077-4871-3-A	7,716 lb	3,527 lb	N/A	6.4"	2.2"	47.2"	80.7"	III	1.8"	15.8"	23.1"	3.3"	465 lb
TFCT-077-5393-3-A	7,716 lb	3,527 lb	2,976 lb	6.4"	2.2"	53.1"	92.5"	III	1.8"	18.4"	27.3"	3"	503 lb
MAXIMUM	11,000 lb	5,060 lb	4,180 lb	--	--	53.1"	92.5"	III	--	--	--	--	--

All dimensional sizes are nominal

Other sizes available upon request.

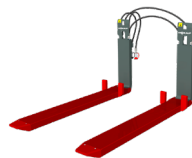

PALLET STOP A1

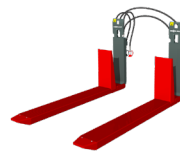

LOAD STOP A2

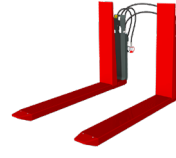

LOAD BACKREST A3

